

Application: metal and not metal sheets.
Assembly: with special hand or pneumatic tools.

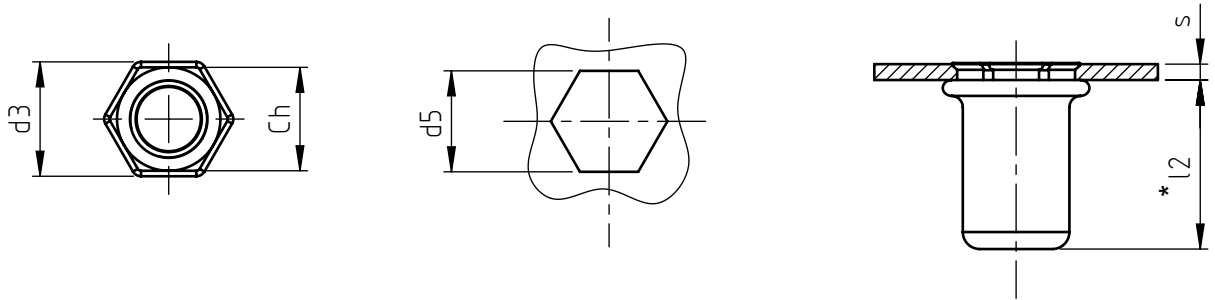

Picture A

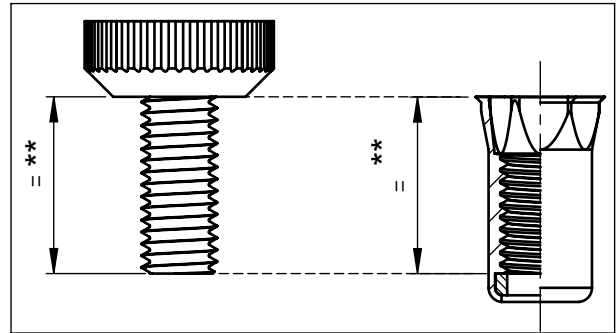
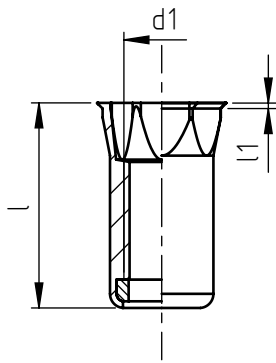

code	s	l +0,50 -0,50	d1 6H	ch	d3	l1 ~	d5 +0,15 0	l2 *
ETFM/A M 5/ _S	0,5 ÷ 3,0	17,5	M 5	9	10	0,7	9	15
ETFM/A/L M 5/ _S	3,0 ÷ 5,5	20,0						
ETFM/A M 6/ _S	0,5 ÷ 3,0	17,5	M 6	9	10	0,7	9	15
ETFM/A/L M 6/ _S	3,0 ÷ 5,5	20,0						
ETFM/A M 8/ _S	0,5 ÷ 3,5	19,5	M 8	11	12	0,8	11	15
ETFM/A/L M 8/ _S	3,5 ÷ 6,0	22,0						

Non binding dimensions, expressed in mm.

* Dimension determined from the average of the grip "s" min and max values.

** The insert has to be screwed on the mandrel for the whole threaded length, avoiding the screw into the nylon washer as highlighted in the picture (A) above.

Standard On demand

Material: blind thread nut steel no.1.0303 / /8S
blind thread nut stainless steel no.1.4567 / /XS
washer nylon

Finishing: blind thread nut steel: zinc-plated
blind thread nut stainless steel: natural
washer natural

Thread: ISO 6 H metric

Example: thread tubular self-locking rivet nut,
low profile head, semi-hexagonal shank,
stainless steel, grip 3,0 mm, M 8 thread:

ETFM/A M 8/XS

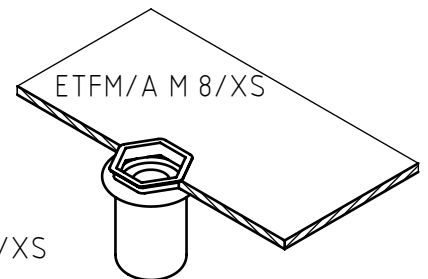

SYSTEM PATENTED

SPECIALINSERT® COMMITS ITSELF TO CONTINUOUSLY IMPROVE ITS PRODUCTS. IT RESERVES THE RIGHT TO CHANGE THEIR TECHNICAL AND STRUCTURAL CHARACTERISTICS WITHOUT PRIOR NOTICE. ALL RIGHTS ARE RESERVED AND THE DUPLICATION, EVEN PARTIAL, OF THESE DOCUMENTS, AS WELL AS ITS DISTRIBUTION TO THIRD PARTIES, ARE FORBIDDEN, UNLESS OTHERWISE AND EXPRESSLY AUTHORIZED BY SPECIALINSERT.