

Application: metal and not metal sheets.  
Assembly: with special hand or pneumatic tools.

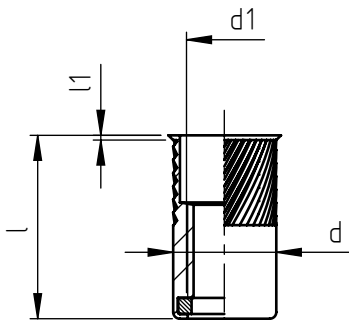

Picture A

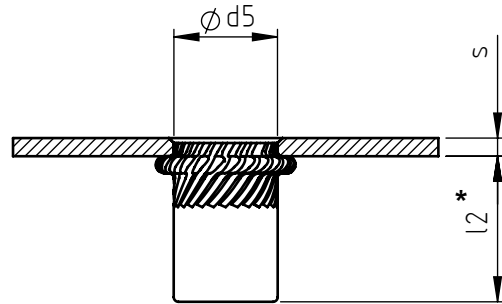
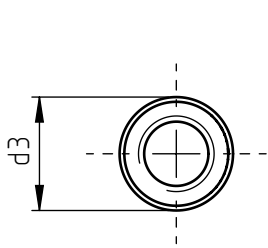
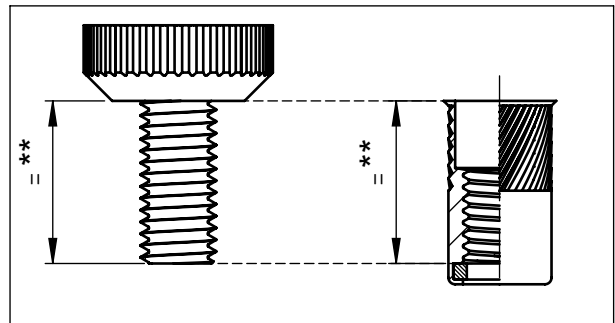

code	s	l +0,50 -0,50	d1 6H	d	d3	l1 ~	d5 +0,15 0	l2 *
TFM/A M 5/ __ZI	0,5 ÷ 3,0	17,5	M 5	9	10	0,6	9	14
TFM/A/L M 5/ __ZI	3,0 ÷ 5,5	20,0						
TFM/A M 6/ __ZI	0,5 ÷ 3,0	17,5	M 6	9	10	0,6	9	14
TFM/A/L M 6/ __ZI	3,0 ÷ 5,5	20,0						
TFM/A M 8/ __ZI	0,5 ÷ 3,5	19,5	M 8	11	12	0,6	11	14
TFM/A/L M 8/ __ZI	3,5 ÷ 6,0	22,0						

Non binding dimensions, expressed in mm.

\* Dimension determined from the average of the grip "s" min and max values.

\*\* The insert has to be screwed on the mandrel for the whole threaded length, avoiding the screw into the nylon washer as highlighted in the picture (A) above.

Standard

On demand

Material: blind thread nut steel no.1.0718 / /8ZI  
blind thread nut stainless steel no.1.4305 / /XZI

Finishing: blind thread nut steel: zinc-plated  
blind thread nut stainless steel: natural  
washer nylon  
washer natural

Thread: ISO 6 H metric

Example: thread tubular self-locking rivet nut,  
low profile head, knurled shank, steel,  
grip 3,0 mm, M 8 thread: TFM/A M 8/8ZI

